



PREPARED BY: _____ DATE _____	<h1 style="text-align: center;">S H A R P</h1> <p style="text-align: center;">LIQUID CRYSTAL DISPLAY GROUP SHARP CORPORATION</p> <h2 style="text-align: center;">S P E C I F I C A T I O N</h2>	SPEC No. LD-2808D
APPROVED BY: _____ DATE _____		FILE No. _____
		ISSUE: Sep. 5. 1990
PAGE : 34 pages		APPLICABLE GROUP Liquid Crystal Display Group

DEVICE SPECIFICATION FOR

T F T - L C D module

MODEL No. **LQ 6 NC 0 1**
LQ 6 NC 0 2

CUSTOMER'S APPROVAL

DATE _____

BY _____

PRESENTED
BY T. Takemoto

T. TAKEMOTO
 Department General Manager
 Engineering Department
 TENRI FACTORY
 LIQUID CRYSTAL DISPLAY GROUP
 SHARP CORPORATION

CONTENTS

	page
(1) Introduction	- 2-
(2) Features	- 2-
(3) Construction and Outline	- 2-
(4) Module geometry	- 3-
(5) Input / Output terminals	- 3-
(6) Absolute maximum ratings	- 6-
(7) Electrical characteristics	- 7-
(8) Optical characteristics	-10-
(9) Mechanical characteristics	-12-
(10) Display quality	-13-
(11) Handling instructions	-14-
(12) Shipping requirements	-16-
(13) Reliability test items	-16-
(14) Others	-18-
 Attached drawings	
Fig. 1 Illustration of TFT-LCD panel	-19-
Fig. 2 Construction of TFT-LCD module	-20-
Fig. 3 Outline dimensions of TFT-LCD module	-21-
Fig. 4 Circuit block diagram of TFT-LCD module	-22-
Fig. 5 Recommended circuit for TFT-LCD module	-23-
Fig. 6 Input/Output signal waveforms	-24-
Fig. 7 Input/Output signal timing chart	-25-
Fig. 8 Optical characteristics measuring method	-26-
Fig. 9 Packing form	-27-
 Attached sheets	
(Appendix-1) Construction of TFT-LCD module	-28-
(Appendix-2) Example of TFT-LCD TV	-30-
(Appendix-3) Adjusting method of optimum common electrode DC bias voltage	-32-

(1) Introduction

Sharp Color TFT-LCD module is the active matrix LCD (Liquid Crystal Display) produced by making the most of Sharp's expertise in **liquid-crystal** and semiconductor technologies.

The active device is amorphous silicon TFT (Thin Film Transistor). The module accepts full color video signals (composite video and analog **RGB**) conforming to the **NTSC(M)** system standard.

When additionally provided with the backlight-driving DC/AC inverter, it is applicable to pocket TVs and various display monitors.

(2) Features

- TFT-active matrix-LCD drive system
- 57,600 pixels (delta configuration)
- **Slim, lightweight** and compact

① **Active-area / Outline-area=57%** ② **Thickness=23mm** ③ **Weight=320g**

“Built-in video interface circuit (including **chroma** demodulator, picture tone, video AGC circuit) and control circuit responsive to composite video signal

- AISO responsive to standard analog RGB video signals

“Further **RGB** signals can be superimposed on composite video signal

(In this case, RGB signals shall be digital input signal for 8 colors display)

- **High** quality full color rendition with backlight source incorporated.

- Viewing angle: 6 o'clock direction. (LQ6NC01)

12 o'clock direction. (LQ6NC02)

(3) Construction and Outline “

The module consists of a **TFT-LCD** panel, driver **ICs**, control PWB mounted with electronic circuits, fluorescent tube, reflector, frame, front case, and rear shielding case.

(Backlight-driving DC/AC inverter is not built in the module.)

- * Illustration of TFT-LCD panel” : See Fig. 1.
- * Construction of TFT-LCD modul : See Fig. 2,
- * Outline dimensions of **TFT-LCD modul** : See Fig. 3.

(4) Module geometry

Table 1

Parameter	Specifications	Unit	Remarks
Display format	57,600	pixels	
	720(W)x240(H)	dots	
Active area	113.8(W)x87.6(H)	mm	
Screen size	5.7(diagonal)	inches	
Dot pitch	0.158(W)x0.365(H)	mm	
Dot configuration	R.G.B Delta configuration	—	
Outline dimension	149.4(W)x117(H)x23(D)	mm	[Note 4-1]
Weight	320±20	g	

【0Note 4-1] Excluding protrusions

(5) Input / Output terminals

5-1) TFT-LCD panel driving section

Table 2

PinNo	Symbol	i/o	Description	Remarks
1	HSY	o	Internal horizontal sync. signal(In phase with VBS)	
2	VSY	o	Internal vertical sync. signal(In phase with VBS)	
3	TST	-	This shall be electrically opened during operation.	
4	NC	-	This shall be electrically opened during operation.	
5	TST	-	This shall be electrically opened during operation.	
6	GND	i	Ground	
7	Vsw	i	Selection signal of two sets of video signals	【Note5-1】
8	GND	i	Ground	
9	V _{CDc}	i	DC bias voltage adjusting terminal of common electrode driving signal	【Note5-2】
10	V _{SH}	i	Positive power supply voltage	
11	V _{BS}	i	Composite video signal	【Note5-3】
12	BRT	i	Brightness adjusting terminal	【Note5-4】
13	CNT	i	Contrast adjusting terminal	"
14	COL	i	Color gain adjusting terminal	"
15	TIN	i	Tint adjusting terminal	"
16	V _{SL}	i	Negative power supply voltage	
17	V _{RI}	i	Color video signal (Red)	【Note5-5】
18	V _{GI}	i	" (Green)	"
19	V _{BI}	i	" (Blue)	"
20	GND	i	Ground	

In the following descriptions, "High" means " V_{sH} " and "Low" means "GND".

【Note5-1】 Selects input signals, composite or RGB

- ① When VSW is "High" or open, composite video signal (Pin No.11) is selected.
- ② When VSW is "Low", RGB signal set (Pin No.17 through 19) is selected.
- ③ When RGB signal is superimposed on the screen of composite signal, "Low"/"High" should be input into this terminal by synchronizing RGB signal.

【Note5-2】 Common electrode driving signal (V_{COM}) generated in the module is observed on the pin. Should be opened during operation, as the DC component of V_{COM} (V_{DC}) is adjusted to the optimum value with V_{sH} and V_{sL} being the typical values on shipping.

But, in case of change of the optimum value (for example, lowering of the power source), it should be re-adjusted by the built-in variable resistor (V_{DC}) or external circuit shown in Fig.5.

Refer to (Appendix-3) "Adjusting method of optimum DC bias voltage" for re-adjusting.

【Note5-3】 Similary in case of RGB input, apply composite video signal or composite sync. signal (with negative polarity) for sync. separator.

【Note5-4】 Brightness, Contrast, Color gain and Tint are adjusted by the DC voltage supplied to each pin. (contrast, color gain, and tint are not available for RGB signal input)

They are adjusted to the optimum value on shipping, but, they can be re-adjusted by the built-in variable resistor (BRT,CNT,COL,TIN) or external circuit shown in Fig.5.

(However, as the contrast is adjusted to maximize display characteristic, it is recommended not to readjust it and to remain outer adjustment terminals open.)

【Note5-5】① Responsive to 0~0.7Vpp analog RGB signal when VSW is fixed to "Low"

- ② In case of superimposing on composite video signal as on screen display(ref;Note5-1), RGB signals shall be digital signal (Low:0Vp-p High:>2Vp-pavailable for 8 colors display)

5-2) Back ight driving section

Table 3

PinNo.	Symbol	i/o	Description	Remarks
L1	VL 1	i	Power supply for fluorescent tube 1 (GND)	【Note5-6】
L2	NC	-	No connection	
L3	VL 2	i	Power supply for fluorescent tube 1 (High)	
L4	VL 3	i	Power supply for fluorescent tube 2 (High)	
L5	NC	-	No connection	
L6	VL 4	i	Power supply for fluorescent tube 2 (GND)	【Note5-6】

【Note5-6】 Should be grounded by the backlight driving DC/AC inverter, as the L1 and L6 terminals are connected with the shielding film in the module. These terminals will be grounded by the optional DC/AC inverter. (For internal electrical connection of backlight unit, see Fig. () below.)

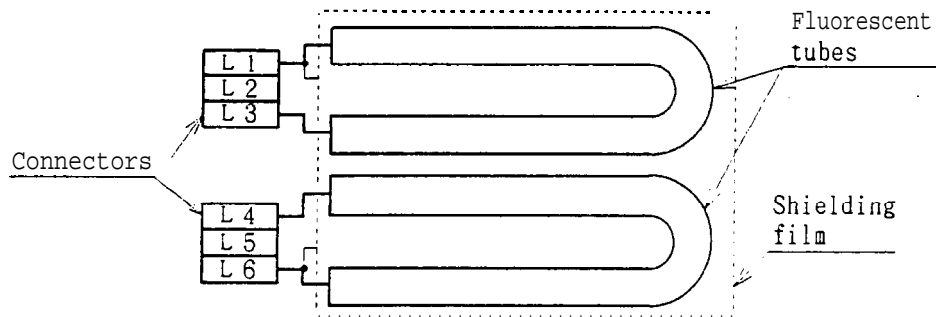

Fig.(i) Wiring diagram of backlight unit

Caution: Shielding case is separated from GND terminal and electrically open.

(6) Absolute maximum ratings

Table 4

GND=0V Ta=25℃

Parameter	Symbol	MIN	MAX	Unit	Remarks	
Positive power supply voltage	V_{sH}	-0.3	+6.0	v		
Negative power supply voltage	V_{sL}	-9.0	+0.3	v		
Video input signal 1	V_{i1}	-	2.0	Vp-p	【Note6-1】	
Video input signal 2	V_{i2}	-	$V_{sH}-0.3$	Vp-p	【Note6-2】	
Digital input/output signals	VI	-0.3	$V_{sH}+0.3$	v	【Note6-3】	
DC bias voltage of common electrode driving signal	V_{CDC}	$V_{sL}-0.3$	-1.5	v		
Picture adjusting terminal voltage	V_{pic}	-0.3	$V_{sH}-0.3$	v	【Note6-4】	
Storage temperature	Tstg	-25	60	℃		
Operating temperature	Panel temp.	Topp	0	60	℃	【Note6-5】
	Ambient temp.	Topa	0	40	℃	

【Note6-1】 VBS terminal (composite video signal)

【Note6-2】 VRI, VGI, VBI terminals (RGB signals)

【Note6-3】 \overline{HSY} , \overline{VSY} VSW terminals

【Note6-4】 BRT, CNT, COL, TIN terminals

【Note6-5】 Maximum wet-bulb temperature 38℃ or less.

No dew condensation.

(7) Electrical characteristics

7-1) Recommended operating conditions

A) TFT-LCD panel section

Table 5

GND=0V Ta=25°C

Parameter	Symbol	MIN	TYP	MAX	Unit	Remarks	
Positive power supply voltage	V_{sH}	+4.8	+5.0	+5.2	V		
Negative power supply voltage	V_{sL}	-7.6	-8.0	-8.4	V		
Video input signal amplitude (peak level)	VBS	0.7	1.0	1.3	Vp-p	【Note7-1】	
	$V_{RGB(1)}$	-	0.7	-	Vp-p	【Note7-2】	
	$V_{RGB(2)}$	2.0	-	4.0	Vp-p	【Note7-3】	
Video input signal DC component	V_{iDC}	-1.0	0	+1.0	v	【Note7-4】	
Digital input voltage	High level	V_{iH}	+3.5	-	V_{sH}	V	【Note7-5】
	Low level	V_{iL}	0	-	+1.5	V	
Digital output voltage	High level	V_{oH}	+3.5	-	V_{sH}	v	【Note7-6】
	Low level	V_{oL}	0	-	+1.5	V	
DC bias voltage of common electrode driving signal	V_{cDC}	-4.5	-3.5	-2.5	V	【Note7-7】	

【Note7-1】 VBS (composite video signal) Input impedance : 75Ω

Amplitude of sync. signal : >0.2Vp-p

【Note7-2】 VRI,VGI,VBI terminals (RGB signals for analog display)

Input impedance : >10kΩ

【Note7-3】 VRI,VGI,VBI terminals (RGB signals for superimposing)

Input impedance : >10kΩ

【Note7-4】 VBS,VRI,VGI,VBI terminals

【Note7-5】 VSW terminal (selection signal of two sets of video signals)

Input impedance : >50kΩ

【Note7-6】 \overline{HSY} , \overline{VSX} terminals (Internal sync. signals).

Load resistance : >20kΩ

【Note7-7】 Adjusted for each module so as to attain maximum contrast ratio.

Refer to Appendix-3 for adjusting.

B) Backlight driving section

Table 6

Ta=25℃

Parameter	Symbol	MIN	TYP	MAX	Unit	Remarks
Lamp voltage	V_L	290	330	370	Vrms	(just for reference)
Lamp current	I_L	6.0	7.0	8.0	mArms	
Frequency	f_L	20		50	kHz	
Kick-off voltage	V_s	—	—	800	Vrms	

※ DC/AC inverter for driving cold cathode fluorescent tube (CCFT) is not built in the module.

DC/AC inverter for external connection (Model No.: LQ0J04) is optionally available.

7-2) Power consumption

Table 7

Ta=25℃

Parameter	Symbol	Condition	MIN	TYP	MAX	Unit	Remarks
Power consumption by the panel section	Positive supply current	I_{sH}	$V_{sH}=+5.0V$	—	+120	+155	mA
	Negative supply current	I_{sL}	$V_{sL}=-8.0V$	-	-90	-120	mA
	Total	W_s		—	1.32	1.73	W
Power consumption by the fluorescent tube section	W_L	On rated lighting	-	4.6	6.0	W	【Note7-9】

【Note7-8】 Excluding power consumption by the backlight.

【Note7-9】 Calculated reference value ($I_L \times V_L$).

7-3) Circuit diagram

The circuit block diagram of TFT-LCD module is shown in Fig.4.

(For detail, refer to (Appendix-1) and (Appendix-2).)

The recommended external circuit of TFT-LCD module is shown in Fig.5.

Caution: Turn on or off the power supply (V_{sH} and V_{sL}) at the same time.

Be sure to supply all power voltages before inputting input signals.

7-4) Input/Output signal waveforms

Shown in Fig. 6

Caution: Input standard composite video (or sync.) signal matching for NTSC(M) system in VBS.

A long time input of non-standard sync. signal may cause flicker or degradation of display quality.

7-5) Input/Output signal timing chart

Shown in Fig. 7

Table 8 shows the timing specifications.

Parameter		Symbol	MIN	TYP	MAX	Unit	Remarks
Horizontal sync.	Input pulse width	τ_{HS1}	4.2	4.7	5.7	μsec	
	Output pulse width	τ_{HS2}	2.3	3.0	4.6	μsec	$f=f_H$ 【Note7-10】
Horizontal sync.phase difference		τ_{pd}	-1.5		1.3	μsec	【Note7-11】
Vertical sync.output pulse width		τ_{Vs}	243	256	269	μsec	$4/f_H$
Vertical sync. phase difference		τ_{pv}	67/33	73/39	79/45	μsec	【Note7-12】

(Supply voltage condition: $V_{SH}=+5V, V_{SL}=-8V$)

【Note7-10】 Adjusted by variable resistor (H-POS).

【Note7-11】 Variable range by variable resistor (H-POS)

(Positive when HSY proceeds VBS.)

Adjusted value : $\tau_{pd}=-0.1 \pm 0.7 \mu\text{sec}$

【Note7-12】 Odd field/Even field ($1/f_H/0.5/f_H$)

7-6) Display time range

(a) Horizontally

10.9- 61.0 μsec from the falling edge of HSY.

(b) Vertically

19~ 258H from the falling edge of VSY.

(8) Optical characteristics

Table 9

Ta=25℃

Parameter	Symbol	Condition	MIN	TYP	MAX	Unit	Remarks
Viewing angle range	$\Delta\theta 11$	$CR \geq 10$	30(10)	-	-	Degree	LQ6NC01
	$\Delta\theta 12$	CR210	10(30)	-	-	Degree	(LQ6NC02)
	$\Delta\theta 2$	$CR \geq 10$	45	-	-	Degree	[Note 8-1,2]
Contrast ratio	CRmax	$\theta = 0^\circ$	30	-	-		[Note 8-2,3]
Response time	Rise	$\theta = 15^\circ$	-	30	-	ms	{Note 8-2}
	Decay		-	50	-	ms	[Note 8-4]
Brightness	Y_L	$\theta = 0^\circ$	100	120	-	nt	[Note 8-5]
Color temperature	K_L		-	7900	-	K	
White chromaticity	x		0.247	0.297	0.347		
	y		0.262	0.312	0.362		

[Note 8-1] Viewing angle range is defined as follows.

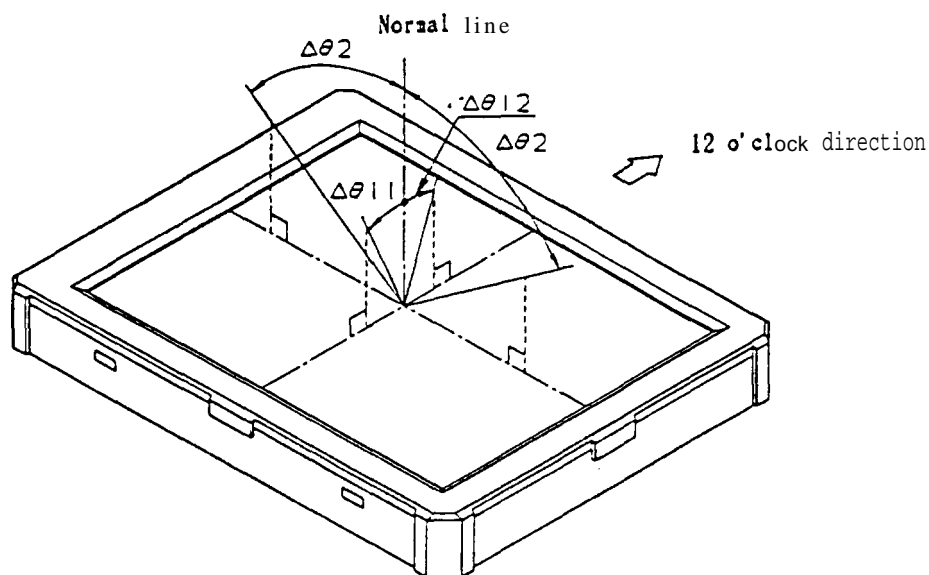

Fig. (ii) " Definition of viewing angle range

[Note 8-2] Applied voltage for measuring optical characteristics

- V_{CDc} must be adjusted by the (1) Flicker measuring method or the (2) Contrast measuring method described in the (Appendix-3) "Adjusting method of optimum common electrode DC bias voltage."
- Brightness adjusting terminal (BRT) should be opened.
- Video signal of reference black level and 100% white level must be input,

[Note 8-3] Contrast ratio is defined as follows,

Contrast ratio is calculated with the following formula in the optical characteristics measuring method shown in Fig. 8.

Contrast ratio (CR)

$$= \frac{\text{Photodetector output with LCD being "white"}}{\text{Photodetector output with LCD being "black"}}$$

[Note 8-4] Input signals are applied to the area measured to make the area "white" and "black" respectively, and change with time in the photodetector output is measured in the optical characteristics measuring method shown in Fig. 8.

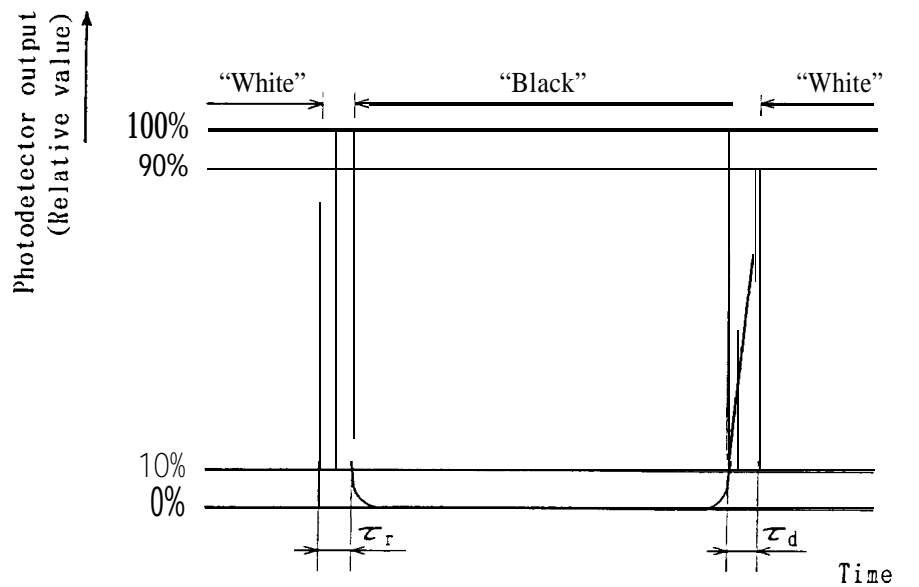

Fig. (iii)

[Note 8-5] Measured on the center area of the panel at a viewing cone 1° by TOPCON luminance meter BM-7.

(9) Mechanical characteristics

9-1) External appearance

There shall not be any conspicuous defects. (See Fig. 3. "Outline dimensions of TFT-LCD module".)

9-2) Panel toughness

The panel shall not break when the panel center is pressed with 2 kg force by 15 mm dia. smooth flat surface.

(Caution): The least force can cause functional troubles if it is applied on the active area for a long time.

9-3) I/O connector performance

A) I/O connector of LCD panel driving circuit (FPC connector 20 pins)

i) Applicable FPC: Shown in Fig. (iv).

ii) Terminal holding force: 100 g or larger/pin

(Each terminal is pulled out at a rate of 25 ± 3 mm/min.)

iii) Insertion/pulling durability: Contact resistance not larger than double the initial value after applicable FPC is inserted and pulled out 20 times.

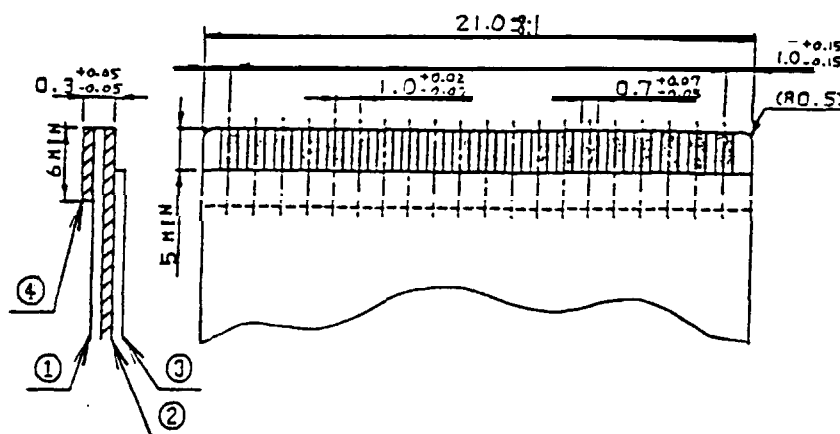

Ref. No	Name	Material
①	Base material	Polyimide or equivalent material (25 μm thick)
②	Copper foil	Copper foil (35 μm thick), solder plated in 2 to 12 μm thickness
③	Coverlay	Polyimide or equivalent material
④	Reinforcing plate	Polyesterpolyimide or equivalent material (188 μm thick)

Fig.(iv) Applicable FPC for I/O connector (1.0 mm pitch)

- B) I/O connector of backlight driving circuit (XH connector 3 pins x2 pcs.)
- l) Applicable connector housing: XHP-3 (produced by Japan Solderless Terminal)
 - u) Terminal holding force: 100 g or more/pin
(Pulled out at a rate of 1 through 5 mm/sec.)
 - ī) Insertion/pulling durability: Contact resistance not larger than double the initial value after connectors are inserted and pulled out 20 times.

(10) Display quality

The display quality of the color TFT-LCD module shall be in compliance with the Delivery Inspection Standard (Separate Sheet LDI-90522).

(11) Handling instructions

11-1) Mounting of module

The TFT-LCD module is designed to be mounted on equipment using the mounting tabs in the four corners of the module rear face.

On mounting the module, as the M3 tapping screw (fastening torque is 5 through 6 kg•cm) is recommended, be sure to fix the module on the same plane, taking care not to warp or twist the module.

Be sure that source of power is off when inserting/pulling out I/O connector of the module.

11-2) Precautions in mounting

① Polarizer which is made of soft material and susceptible to flaw must be handled carefully. Protective film (laminator) is applied on the surface to protect it against scratches and dirt. It is recommended to peel off the laminator immediately before the use, taking care of static electricity.

② Precautions in peeling off the laminator

A) Forking environment

When the laminator is peeled off, static electricity may cause dust to stick to the polarizer surface. To avoid this, the following working environment is desirable.

a) Floor: Conductive treatment of 1 M Ω or more on the tile
(Conductive mat or conductive paint on the tile)

b) Clean room free from dust and with an adhesive mat on the doorway

c) Humidity: 50 % to 70 % RH

d) Workers shall wear conductive shoes, conductive work clothes, conductive gloves and an earth band.

B) Working procedures

a) Direct the wind of discharging blower somewhat downward to ensure that module is blown sufficiently. Keep the distance between module and discharging blower within 20 cm. (See Fig. (v-i).)

b) Attach adhesive tape to the laminator part near discharging blower so as to protect polarizer against flaw. (See Fig. (v -ii).)

c) Peel off laminator, pulling adhesive tape slowly to your side taking 5 or more second.

d) On peeling off the laminator, pass the module to the next work process to prevent the module to get dust.

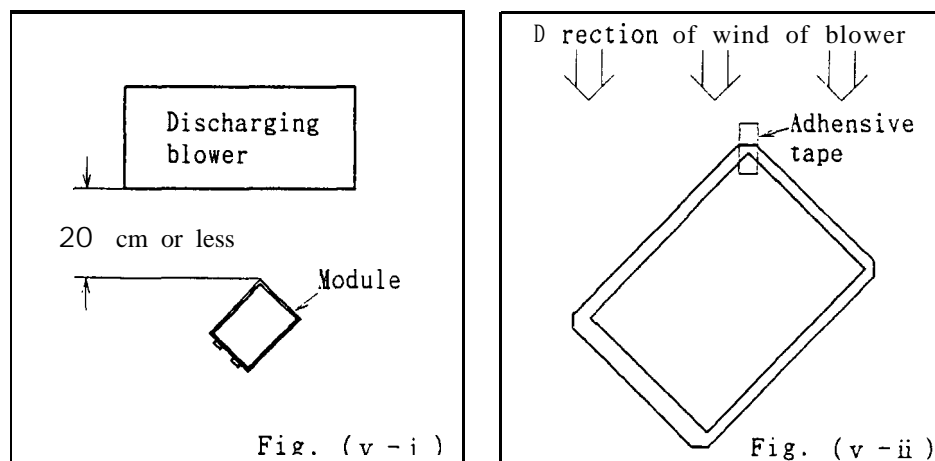

Fig. (v)

e) Method of removing dust from polarizer

① Blow off dust with N_2 blower for which static electricity preventive measure has been taken. Ionized air gun (Hugle Electronics Co.) is recommended.

“ Since polarizer is vulnerable, wiping should be avoided. If wiping is unavoidable, wipe it carefully with lens cleaning cloth, breathing on it. "Belleseime"(Kanebo, Ltd.) is desirable.

- ③ When metal part of the TFT-LCD module (shielding lid and rear case) is soiled, wipe it with soft dry cloth. For stubborn dirt, wipe the part, breathing on it.
- ④ Wipe off water drop or finger grease immediately. Long contact with water may cause discoloration or spots.
- ⑤ TFT-LCD module uses glass which breaks or cracks easily if dropped or bumped on hard surface. Handle with care.
- ⑥ Since CMOS LSI is used in this module, take care of static electricity and earth your body when handling.

11-3) Precautions in adjusting module

Adjusting volumes on the rear face of the module have been set optimally before shipment. Therefore, do not change any adjusted values. If adjusted values are changed, the specifications described here may not be satisfied.

11-4) Others

- ① Do not expose the module to direct sunlight or intensive ultraviolet rays for many hours; liquid crystal is deteriorated by ultraviolet rays.
- ② Store the module at a temperature near the room temperature. At lower than the rated storage temperature, liquid crystal solidifies, causing the **panel** to be damaged. At higher than the rated storage temperature, liquid crystal turns into isotropic liquid and may not recover.
- ③ If LCD **panel** breaks, there may be a possibility that the liquid crystal escapes from the panel. Since the liquid crystal is injurious, do not put it into the eyes or mouth. When liquid crystal sticks to hands, feet or clothes, wash it out immediately with soap.
- ④ Observe all other precautionary requirements in handling general electronic components.

(12) Shipping requirements

12-1) Packing form is shown in Fig. 9.

12-2) Carton storage condition

- ① Number of layers of cartons in pile : 10 **layers** Max.
- ② Environmental condition :
 - °Temperature 0 ℃ to 40 ℃
 - °Humidity 60 %RH or less (at 40 ℃)
No dew condition even at a low temperature and high humidity
 - °Atmosphere Harmful gases such as acid and alkali which corrode electronic components and wires must not be detected.
 - °Storage period About 3 months
 - °Opening of package To prevent TFT-LCD module from being damaged by static electricity, adjust the room humidity to 50 %RH or higher and provide an appropriate measure for electrostatic earthing before opening the package.

(13) Reliability test items

Reliability test items for the TFT-LCD module are shown in Table 10.

Reliability Test Items for TFT-LCD Module

Table 10

No	Test items	Conditions
1	High temperature storage test	T a = 60 °C 240 H
2	Low temperature storage test	T a = -25 °C 240 H
3	High temperature and high humidity operation test	T a = 40 °C · 95 % R H 240 H
4	High temperature operation test	T a = 40 °C 240 H
5	Low temperature operation test	T a = 0 °C 240 H
6	Electrostatic discharge test	± 200 V · 200 pF (0 Ω) Once for each terminal
7	Shock test	100 G · 6 ms, ±X;±Y;±Z 3 times for each direction (JIS C7021, A-7 Condition C)
8	Vibration test	Frequency range : 10 ~ 55 Hz Stroke : 1.5 mm Sweep II) HZ - 55 HZ - 10 HZ 2 hours for each direction of X,Y,Z (6 hours in total) (JIS C7021, A-10 Condition A)
9	Heat shock test	-25 °C ~ +60 °C / 5 cycles (2 hours/cycle) (1 H) (1 H)

[Result Evaluation Criteria]

Under the display quality test conditions with normal operation state, there shall be no change which may affect practical display function.

(14) Others

If any problem occurs in relation to the description in the present specifications or other relevant items, it shall be eliminated in all sincerity through discussion.

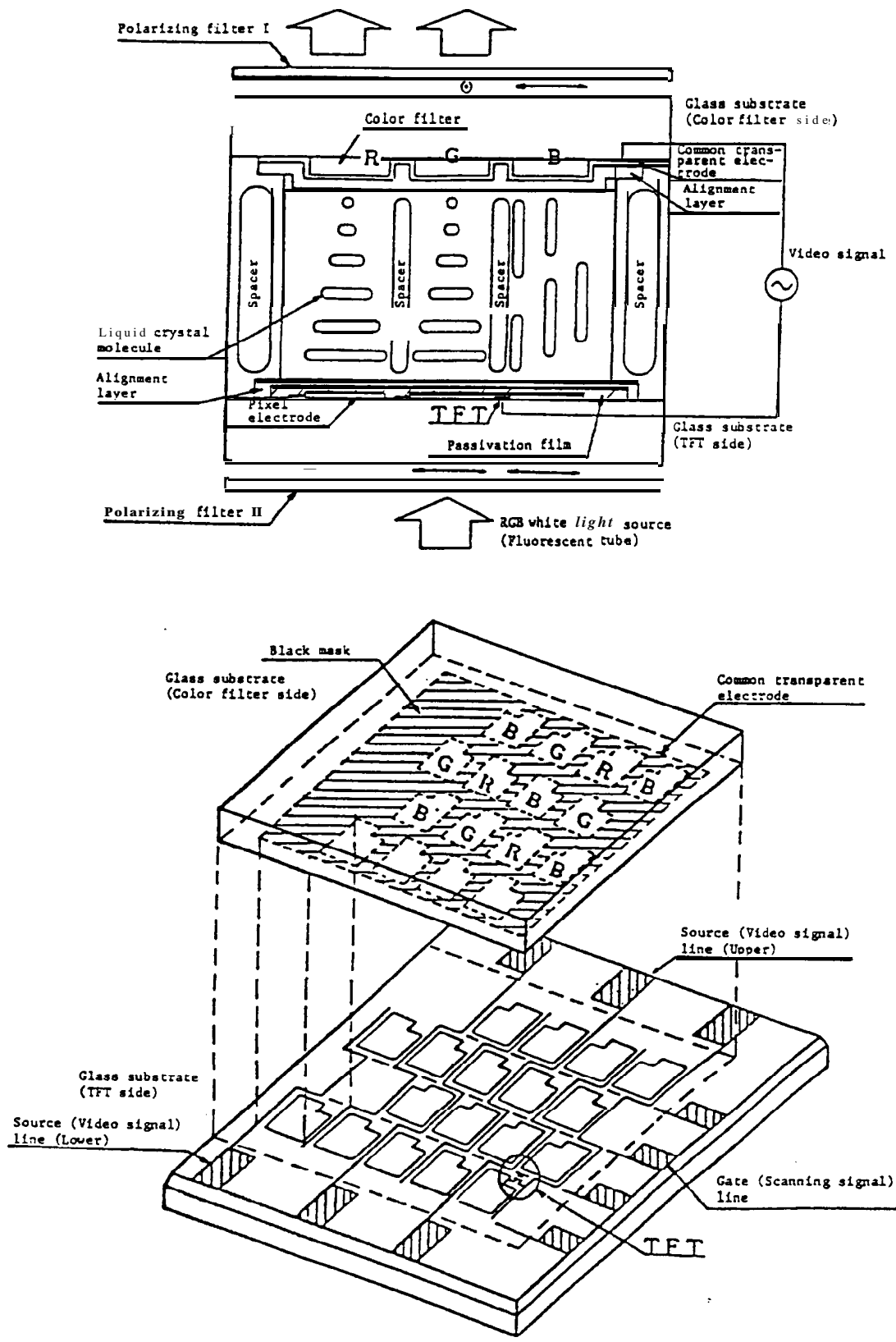

Fig. 1 Illustration of TFT-LCD panel

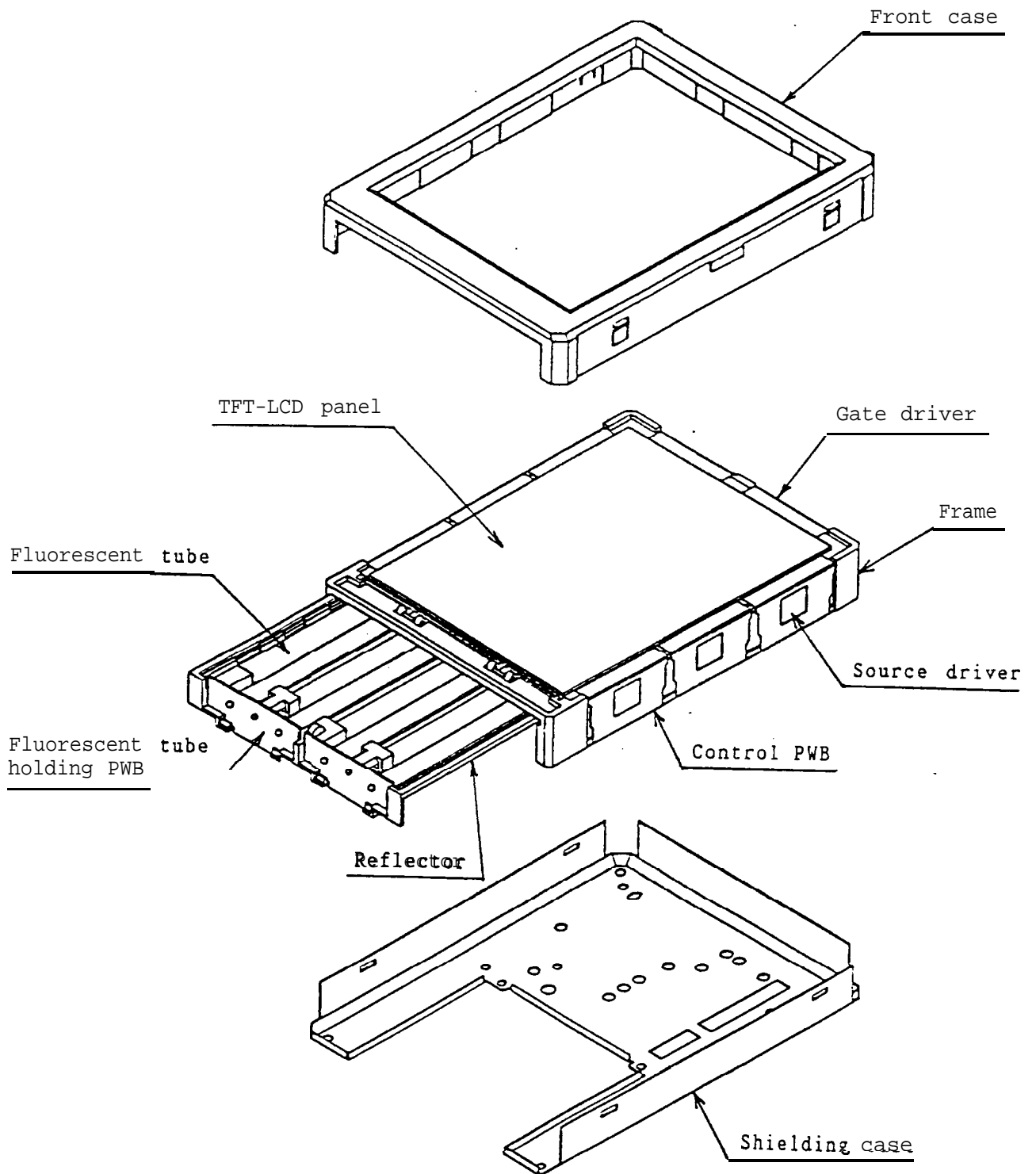

Fig. 2 Construction of TFT-LCD module

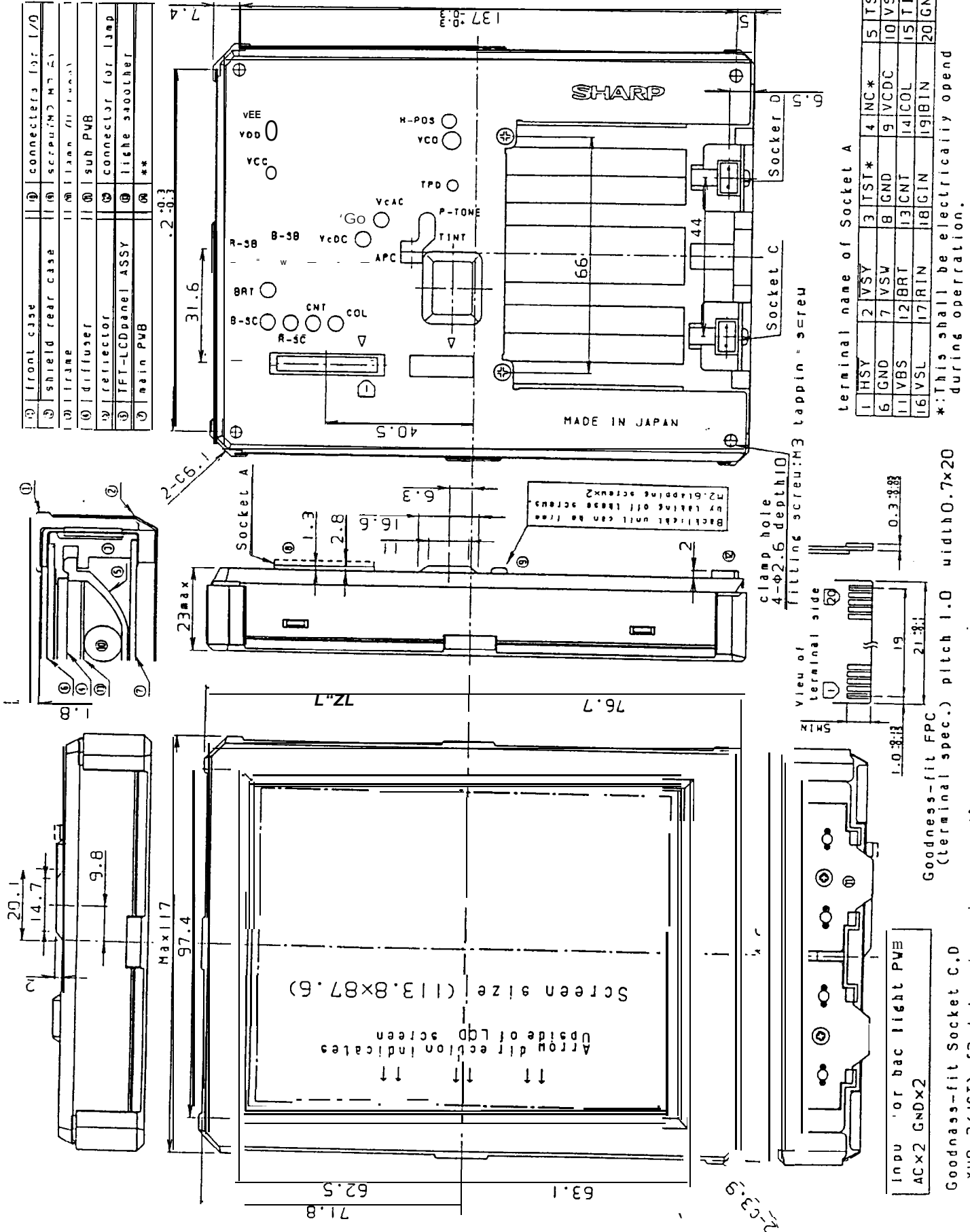

Fig. 3 Out line dimensions of TFT-LCD module

unit:mm

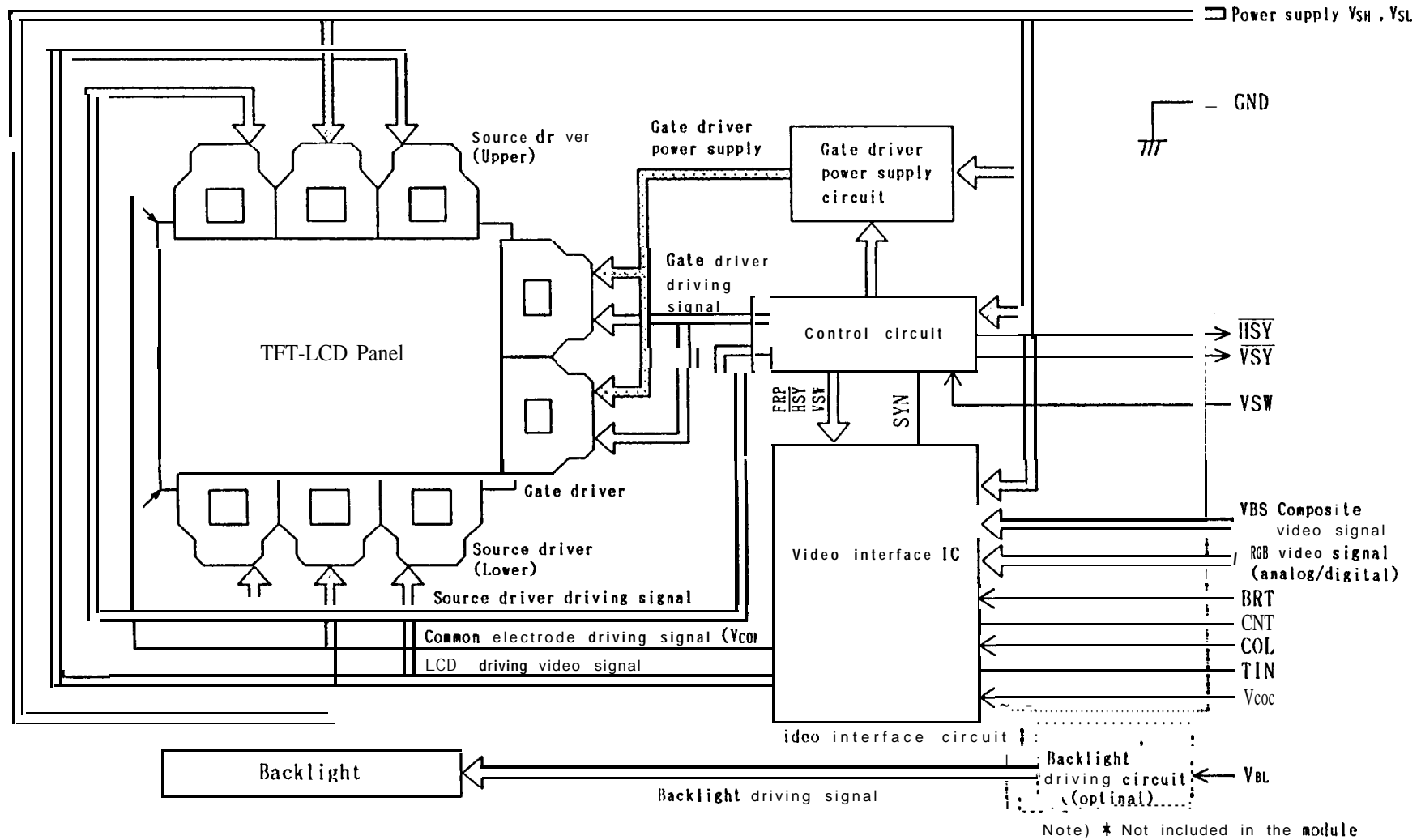

Fig. 4 Circuit block diagram of TFT-LCD module

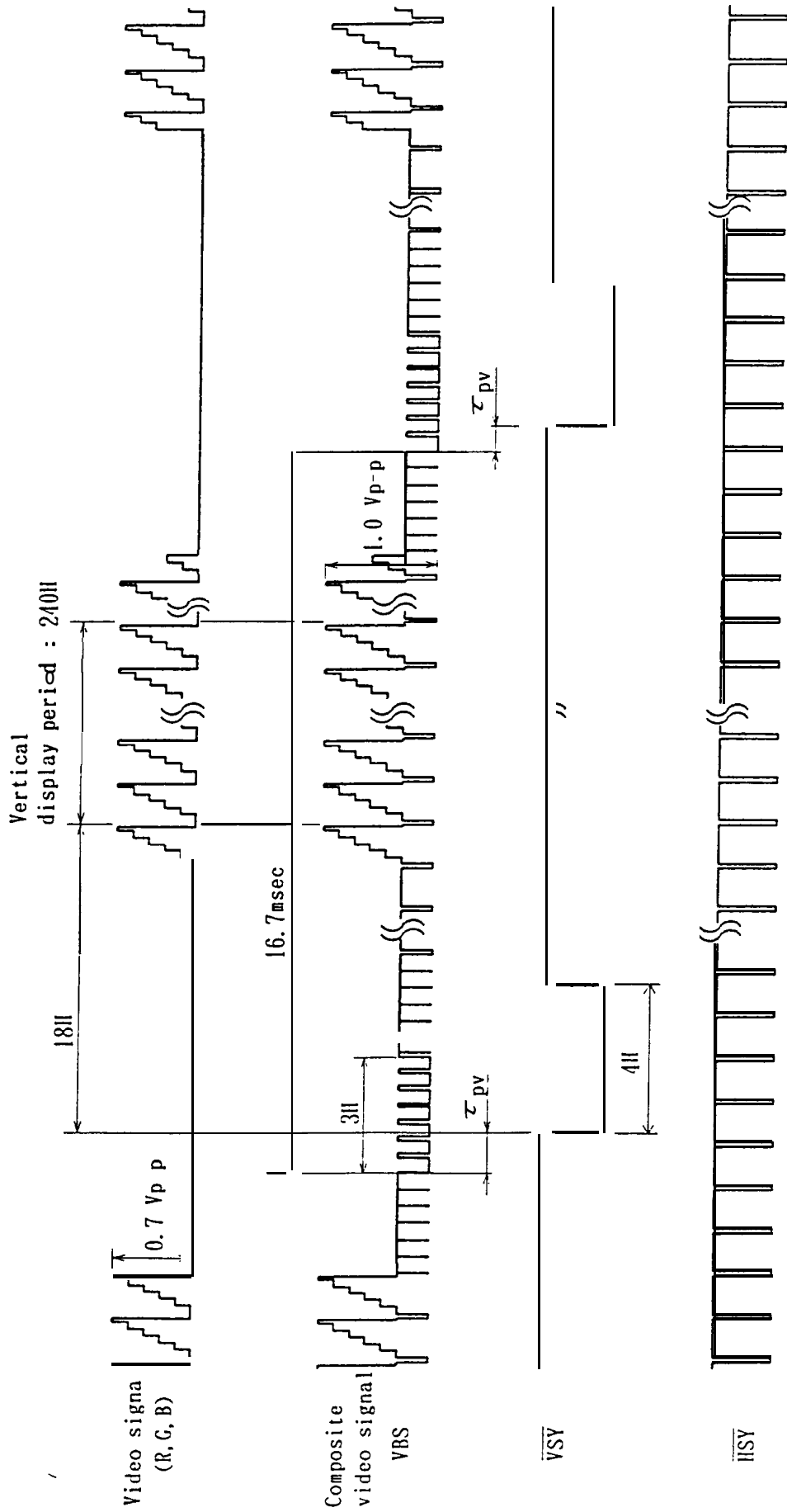

Fig. 6 Input/output signal waveforms

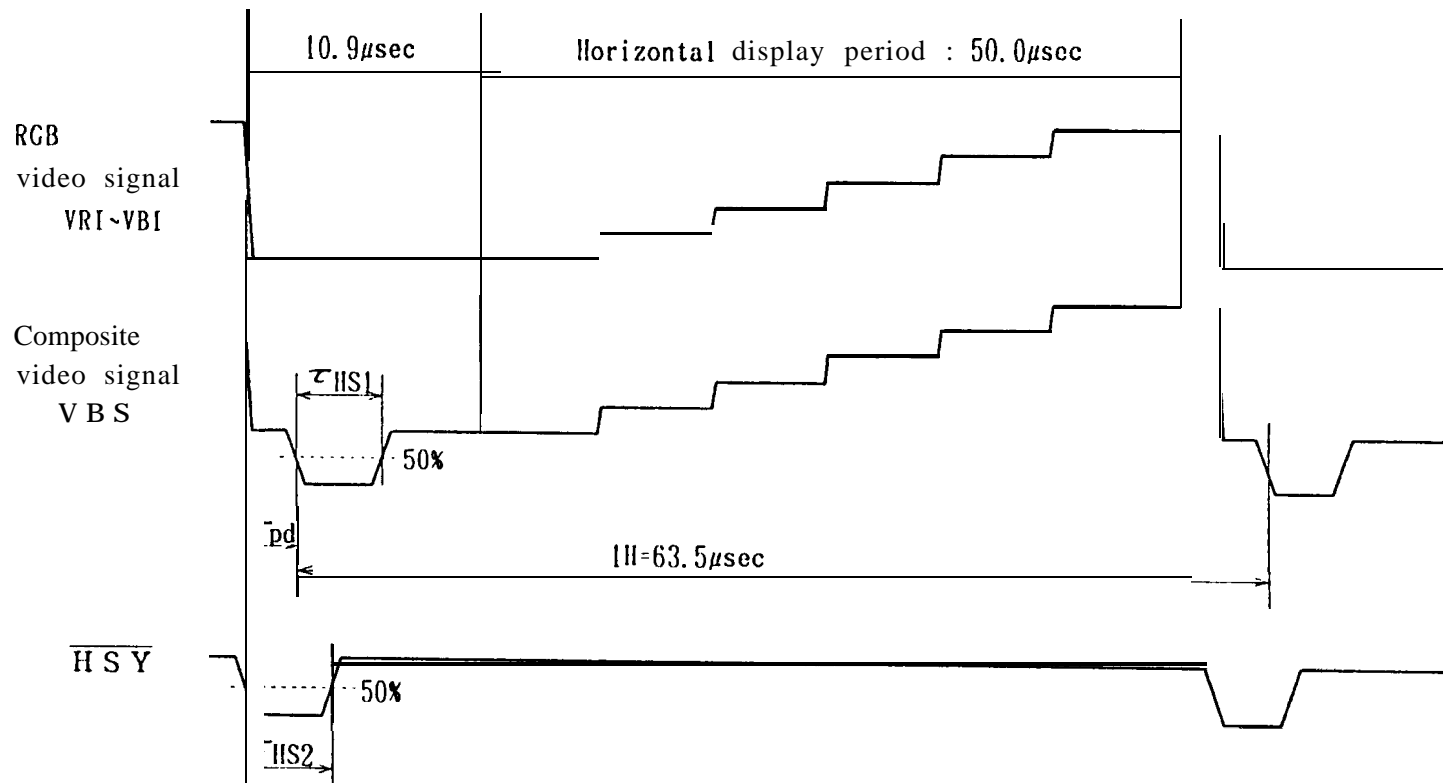

Fig. 7 Input/output signal timing chart

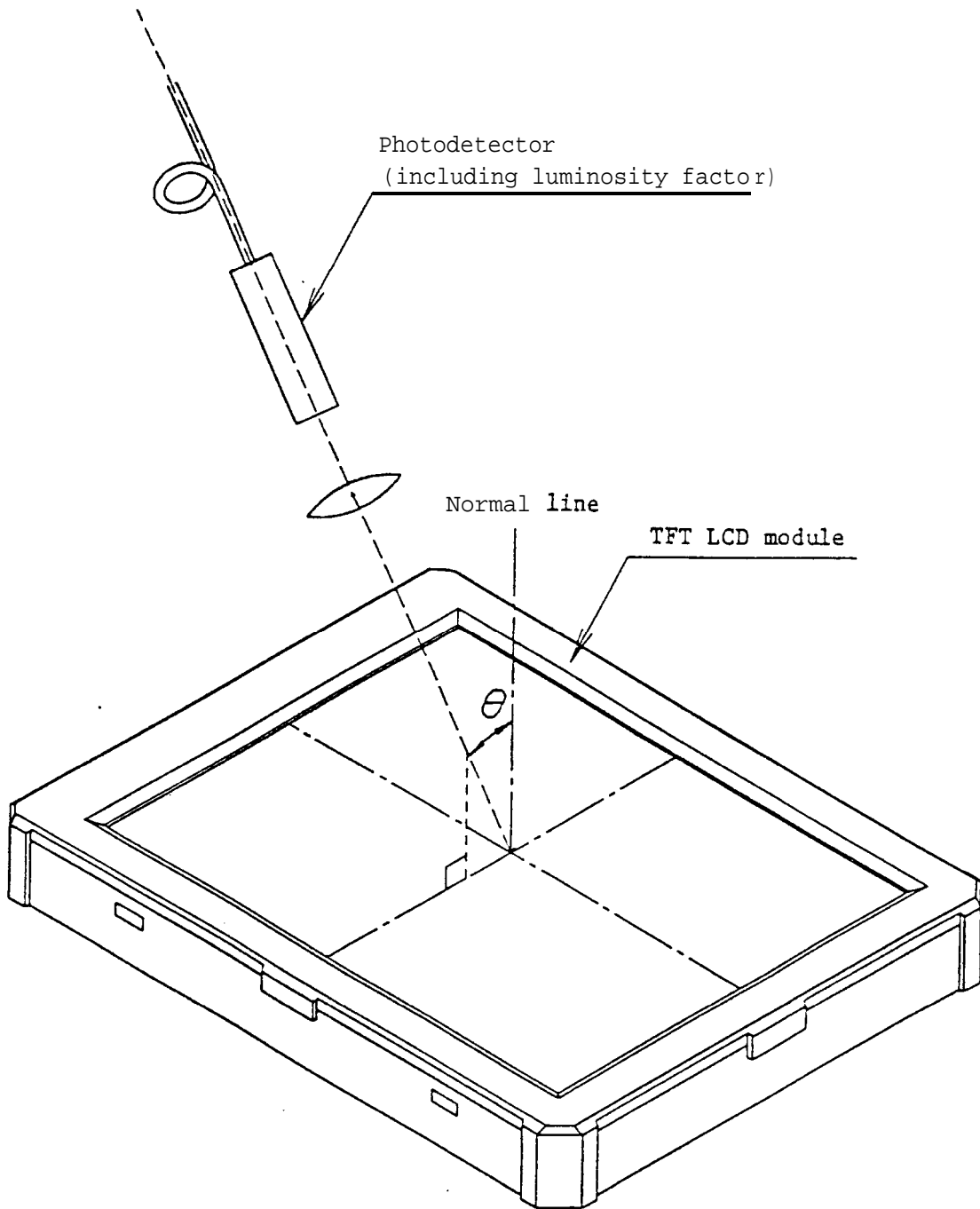

Fig. 8 Optical characteristics measuring method

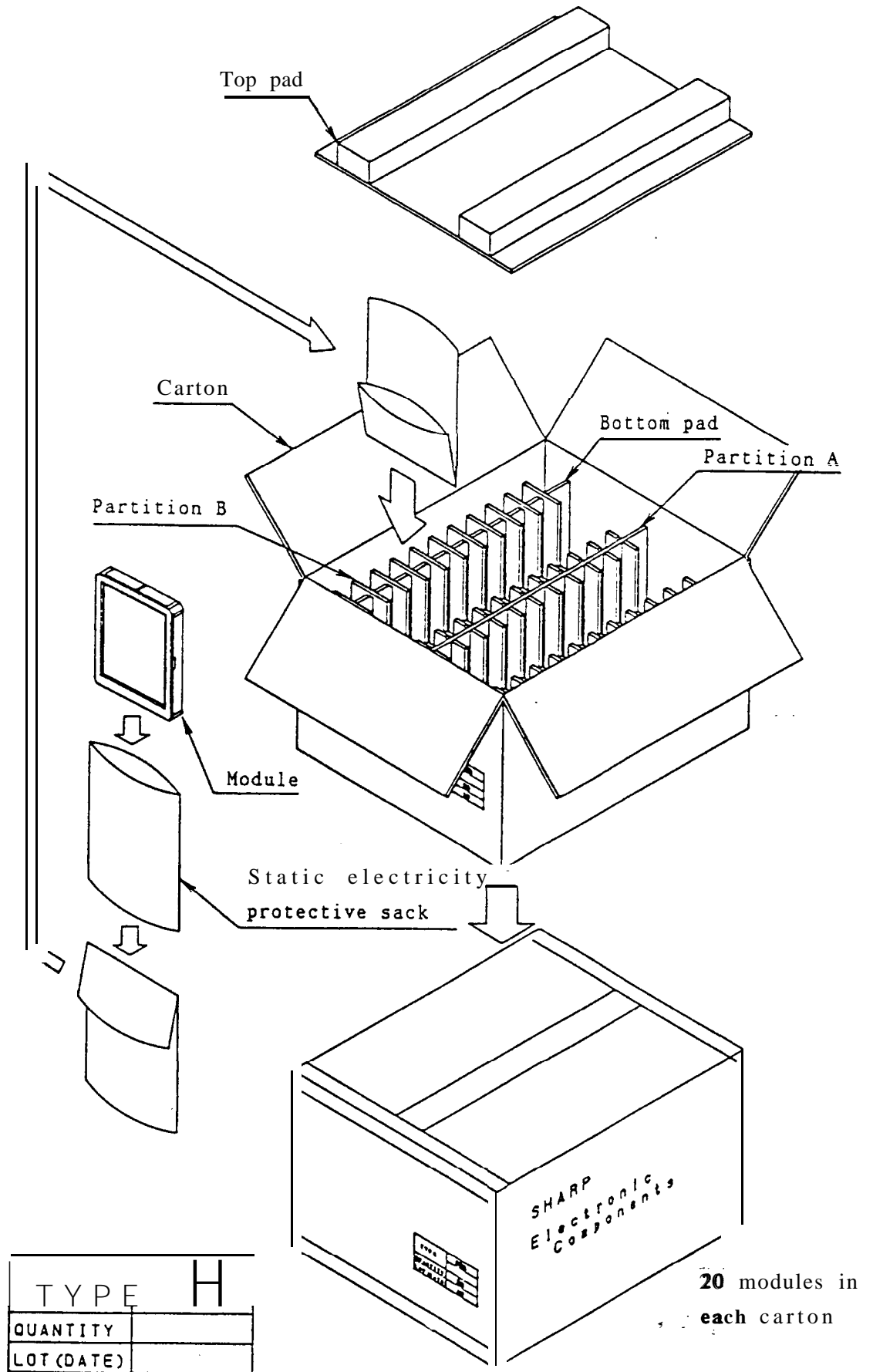

Fig. 9 Packing form

(Appendix-1)

《 Construction of TFT-LCD module 》

TFT-LCD module is composed of an LCD panel, driver ICS for the LCD panel, a control circuit for the driver ICS, a video signal processing circuit (video interface circuit) peculiar to LCD, and a backlight,

The driver ICS are divided into two types: a source driver (data driver) which receives R•G•B signals and sends them sequentially by one horizontal line of the LCD panel, and a gate driver (scan driver) which scans 240 gate lines of the LCD panel.

The circuit diagram is shown in Fig.4.

The module displays an image on LCD panel as it receives power supplies (V_{sH} , V_{sL}), composite video signal, R•G•B video signals, DC bias voltage of common electrode driving signal (V_{cDC}), selection signal of composite and R•G•B video signals (VSW), brightness adjusting DC voltage (BRT), color gain adjusting DC voltage (COL), tint adjusting DC voltage (TIN), and contrast adjusting DC voltage (CNT), from the exterior.

The composite video signal is subject to synchronous separation in the module and used to write a video signal accurately on each pixel on the module.

The control circuit receives composite synchronizing signal separated in the video interface circuit, generates clock pulses synchronized with the composite synchronizing signal and gate and source drivers-driving signals, and outputs internal horizontal synchronizing signal (\overline{HSY}), internal vertical synchronizing signal ($\overline{VS\bar{Y}}$) and polarity inversion signal (FRP).

The voltage level of R•G•B video signals applied to the liquid crystal layer of each pixel through the source driver.IC and TFT is about 3.7 Vp-p from black to white level. In order to prevent the electro-chemical decomposition of the liquid crystal, it is necessary to apply AC voltage to the liquid crystal. For this purpose, the polarity of the video signals must be alternated. Since the amplification and polarity inversion of the video signals are performed in the video interface circuit in the module using the polarity inversion signal (FRP), composite video signal of 1.0 Vp-p or standard analog R•G•B signals of 0.7 Vp-p may be used for both of the inputs to the module.

Power supplies to this module are ① 5 V (V_{sH}), ② 0 V (GND), and ③ -8 V (V_{sL}). Control IC operates on 0 to 5 V line so that it outputs \overline{HSY} and $\overline{VS\bar{Y}}$ at 0 to 5 V level. Power supplies to the video interface circuit are V_{sH} and V_{sL} .

VSW is used to select composite or R•G•B video signals. VSW selects composite video signal when it is "High" or open, and selects R•G•B signals when it is "Low".

BRT, COL, TIN, CNT, and V_{cDc} are adjusted to the optimum value on shipping.

The module contains backlight (cold cathode fluorescent tubes) but not a driving circuit for the backlight. Therefore, it is necessary to install a DC/AC inverter for driving the fluorescent tubes,

Standard DC/AC inverter (Model name: LQ0J04) is available as an option.

In addition, the backlight of the module is designed to be replaceable, and backlight unit (Model name: LQ0B04) is available as a service part for the replacement.

(Appendix-2)

《 Example of TFT-LCD TV 》

Fig.A shows a block diagram example of the TFT-LCD module applied to a TV set.

The block enclosed by  is the TFT-LCD module.

Other signal processing systems are the same as those in ordinary CRT-TVs.

The following seven signals must be supplied to this module from the exterior:

- ① Composite video signal: VBS
- ② Standard analog R•G•B video signals
- ③ Signal for selecting input video signals: VSW
- ④ DC bias voltage of common electrode driving signal: V_{CDc}
- ⑤ Brightness adjusting DC voltage: BRT
- ⑥ Color gain adjusting DC voltage: COL
- ⑦ Tint adjusting DC voltage: TIN

The following two signals are output from this module to the exterior.

- ① Internal horizontal synchronizing signal: HSY
- ② Internal vertical synchronizing signal: VSY

When this module is applied to a TV set, for example, HSY and VSY are used to display selected channel number and characters on the screen.

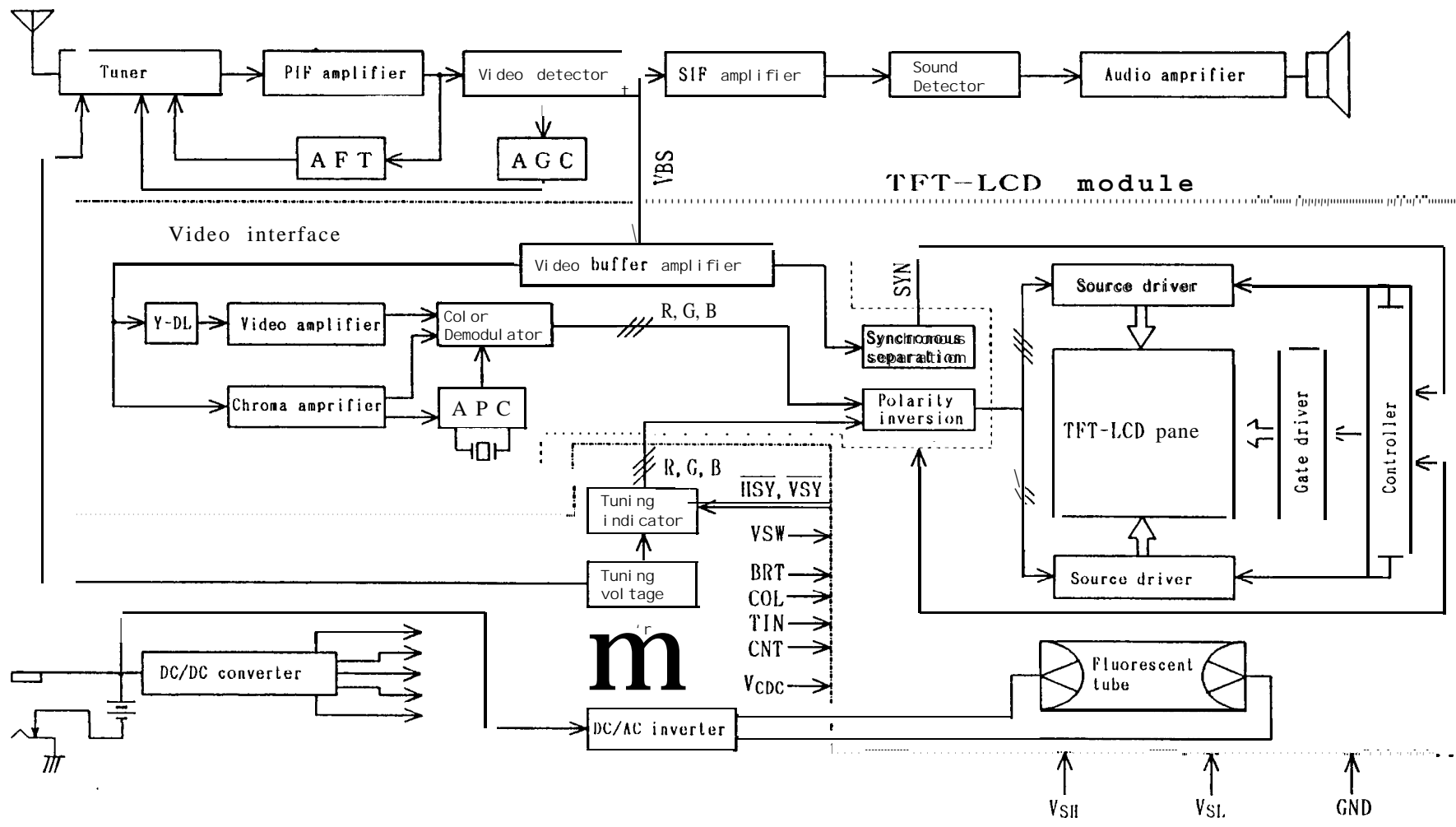

Fig. A Block diagram of TFT-LCD TV set

(Appendix-3)

Adjusting method of optimum common electrode DC bias voltage

To obtain optimum DC bias voltage of common electrode driving signal ($V_{CD C}$), photo-electric devices are very effective, and the accuracy is within 0.1V.

(In visual examination method, the accuracy is about 0.5V because of the difference among individuals.)

To gain optimum common electrode DC bias voltage, there are two methods which use photo-electric devices. The value of optimum DC bias voltage is the same in both methods.

① Measurement of flicker

DC bias voltage is adjusted so as to minimize 60Hz(30Hz) flicker.

② Measurement of contrast

DC bias voltage is adjusted so as to Minimize the photo-electric output voltage.

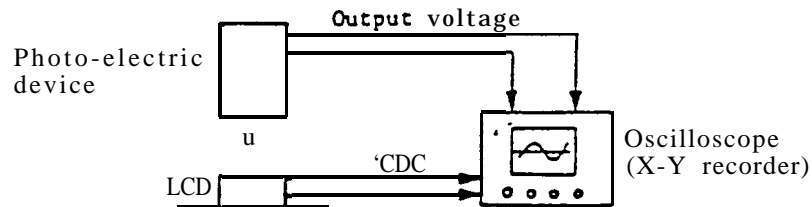

Fig.B Measurement system

(1) Measurement of flicker

Photo-electric output voltage is measured by an oscilloscope at a system shown in Fig.B.

DC bias voltage must be adjusted so as to minimize the 60Hz(30Hz) flicker with DC bias voltage changing slowly. (Fig,C)

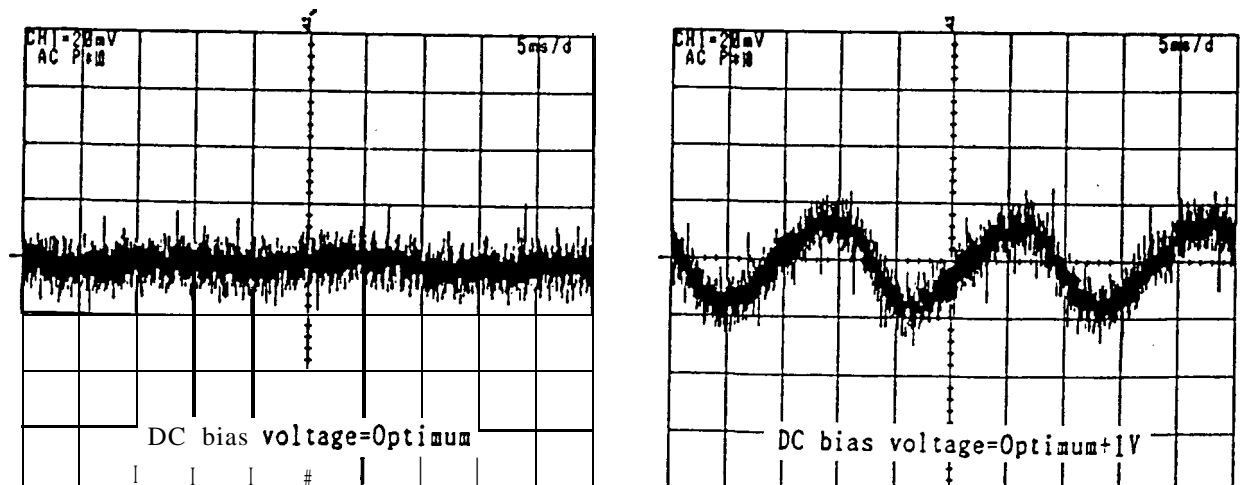

Fig.C Waveforms of flicker

(2) Measurement of contrast

Photo-electric output voltage is measured by oscilloscope or X-Y recorder by using the system in Fig.A. Common electrode DC bias voltage must be adjusted so as to minimize the photo-electric output voltage with DC bias voltage changing slowly. (Fig.D)

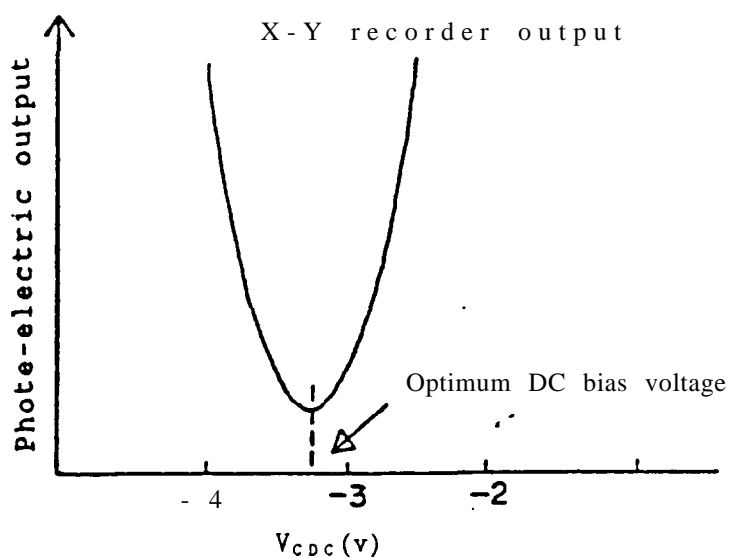

Fig.D Optimum common electrode DC bias voltage by measurement of contrast

(3) Notes

- ① Measurement is more accurate at half tone as compared with other gradation level.
(Change of photo-electric output is small at black level.) see Fig.E.
- ② DC bias voltage must be adjusted slowly. The value of optimum common electrode DC bias voltage changing fast is different from that with changing slowly.
Because DC response is slow. see Fig.F.
- ③ The final adjustment of DC bias voltage must be made by changing from positive to negative.

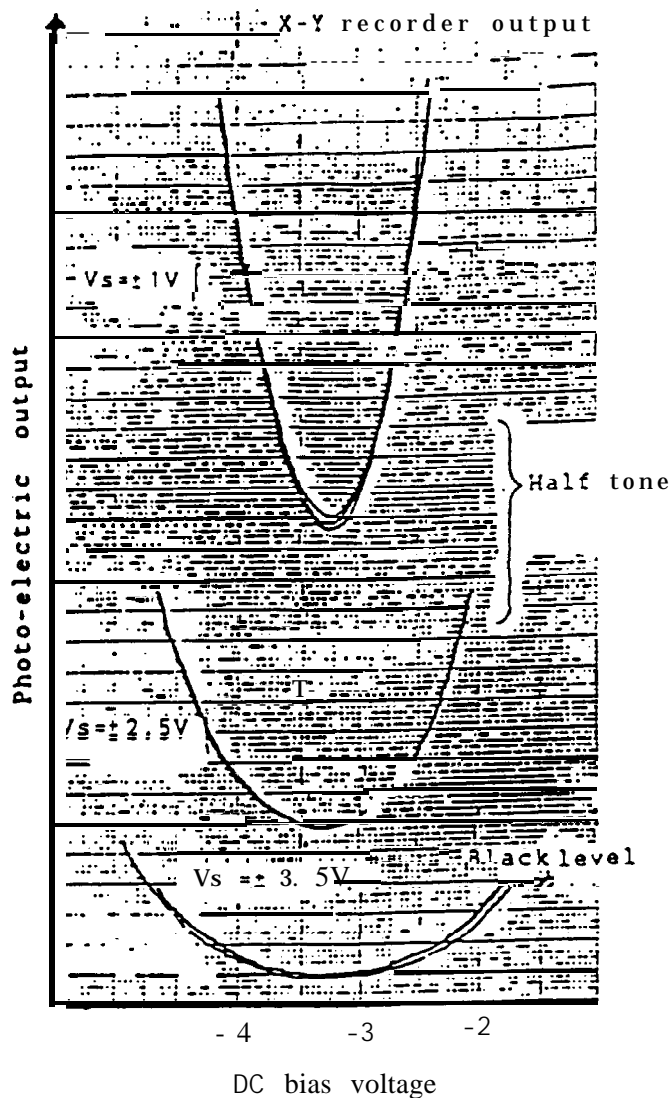

Fig. E Relation between gradation level and DC bias voltage

Optimum common electrode, DC bias voltage is almost equal between half tone and black level.

But it is difficult to decide the optimum point at black level.

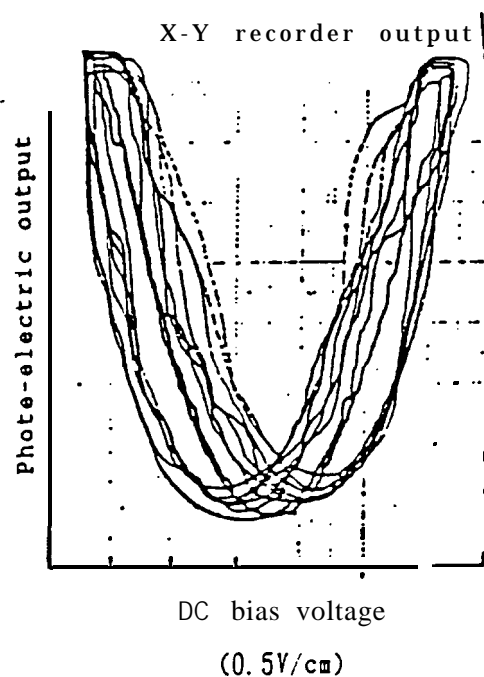

Fig. F Output voltage with DC bias voltage changing fast

The value of minimum point is not definite because DC response is slow. And optimum point cannot be attained.